

CUT COSTS OF FEEDING STOVER



MAIZE, STOVER AND OTHER CROP RESIDUES
AFTER HARVEST MAKE USEFUL FEED FOR
ANIMALS. THE COST OF TRANSPORTING
CAN BE VERY HIGH. BUT NOW...

WHICH OF THESE 2 TRUCKS LOOKS AS IF IT IS CARRYING THE MOST STOVER?



Truck 1 is carrying only 160 kgs of stover

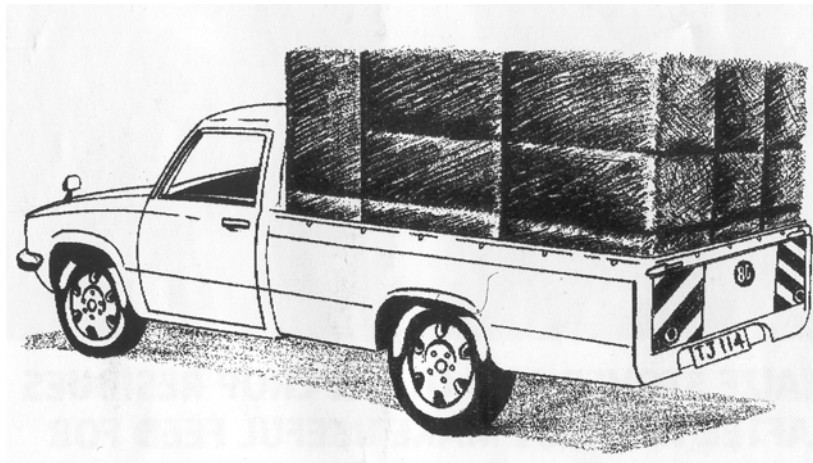

Truck 2 is carrying 260 kgs of stover

REDUCE TRANSPORT COSTS BY A THIRD

- BOX BALE YOUR STOVER

1. MAKE A BOX.

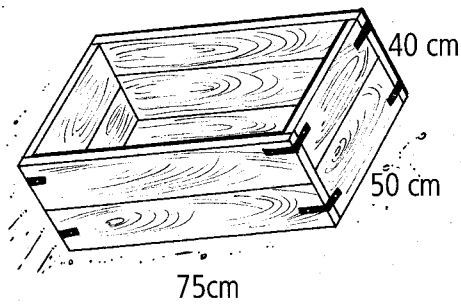

2. PUT SISALTWINE IN.

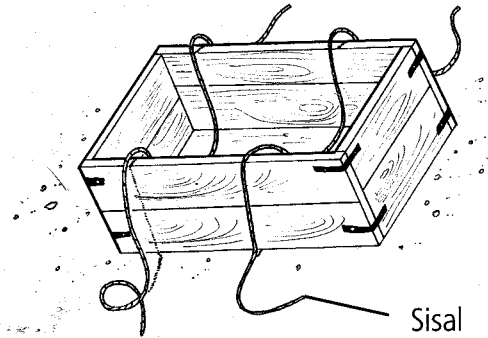

3. PUT IN STOVER AND JUMP ON IT UNTIL AS MUCH AS POSSIBLE IS IN THE BOX.



4. TIE UP THE BOX



5. REMOVE THE BALE. STACK AND STORE WITH EASE.



If only leaves are baled, then you can bale even more!
Leave the stems, as they make poor feed

BOX BALING SAVES BIG MONEY!

Illustrations by: Joseph Kariuki

Technical Content by:

Nicholaus Massawe (Selian Agricultural Research Institute), Emyr Owen (Reading University),
Luis Mtenga (Sokoine University of Agriculture), Dannie Romney (Natural Resources Institute and ILRI),
Sarah Holden and Steve Ashley (Livestock in Development)

For Further Information: Contact The Zonal Director, Selian Agricultural Research Institute

P.O. Box 6024, Arusha Tanzania

Design by: Development Communications Ltd.

Funded by: DFID Livestock Production Programme. Managed by: Natural Resources International Ltd.